

SPIKA NG

ITV |
ICE makers



DESPIECE / REPUESTOS
EXPLODED VIEW / SPARE PARTS
EXPLOSIONSZEICHNUNG / ERSATZTEILE
VUE ÉCLATÉE / PIÈCES DÉTACHÉES
ESPLOSO / RICAMBI

ITV | **ICE** makers **SERVICE** 

CABINET



SPIKA NG

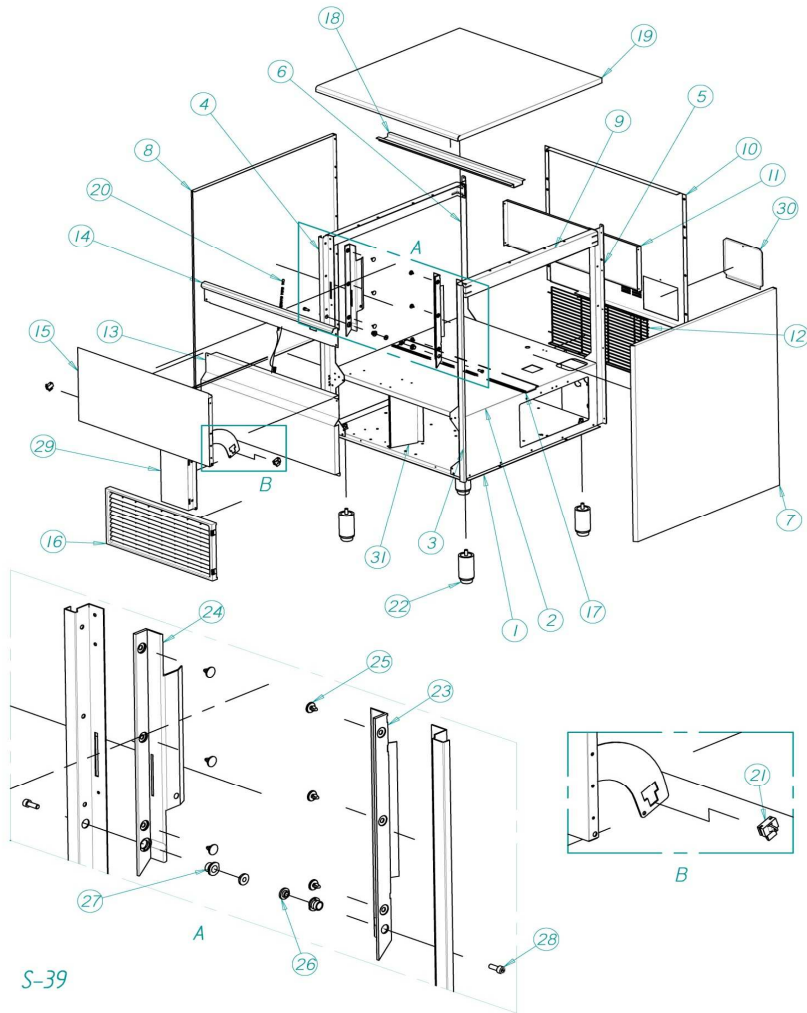

S-39

		DESCRIPTION			
		125	175	215	285
1	BASEMENT	4160	6256	6257	
2	BRIDGE	4159	6258	6259	
3	FRONT RIGHT COLUMN	159	6260		
4	FRONT LEFT COLUMN	160	6261		
5	REAR RIGHT COLUMN	32215	32216		
6	REAR LEFT COLUMN	161	6262		
7	RIGHT PANEL	6466	6285	6287	
8	LEFT PANEL	6467	6286	6288	
9	BRACE	557	3778	6297	
10	REAR COVER	4172	6300	6301	
11	REAR REINFORCEMENT	4171	-	-	
12	REAR GRILL	4088	6209	2192	
13	LOWER FRONT PANEL	4168	6279	6280	
14	UPPER FRONT PANEL	4169	6281	6282	
15	DOOR	5791	6295	6296	
16	FRONT GRILL		4186	4188	
17	BRIDGE REINFORCEMENT	1144	6310	6311	
18	COVER REINFORCEMENT	-	6305	6307	
19	TOP PANEL	4170	6283	6284	
20	DOOR SPRING		702		
21	DOOR BUMPER		156		
22	LEG		1478		
23	RIGHT DOOR GUARD		82		
24	LEFT DOOR GUARD		83		
25	CLIP		113		
26	DOOR AXE BUSHING		155		
27	DOOR AXE BEARING		1001		
28	DOOR SCREW		392		
29	GRILL ADDON	-	6312	6313	
30	LID		6306		
31	AIR DEFLECTOR	-	6366	4975	

SNG 125 BIN & HIDRAULICS PARTS



SPIKA NG

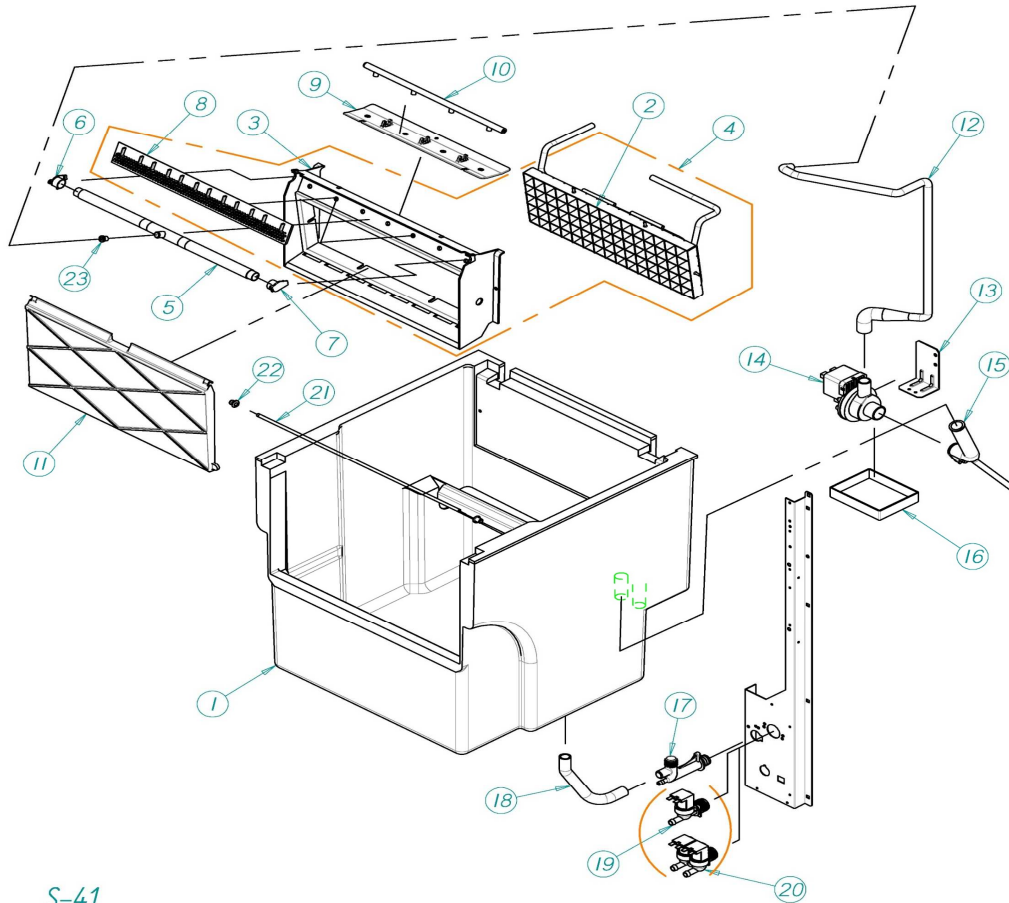

DESCRIPTION		MODEL
1	STOCK BIN	125
EVAPORATOR		
2		1" 6224
		1/2" 6227
3	FRAME	2531
FRAME AND EVAPORATOR ASSEMBLY		
5	COMPLETE WATER DISTRIBUTOR	30041A
4	COMPLETE WATER DISTRIBUTOR before 18233810	30041AK
6	LEFT DISTRIBUTOR CAP	2537A
7	RIGHT DISTRIBUTOR CAP	2538A
8	FLOW DISPERSION RAMP	2530
9	WATER INLET SUPPORT	6099
10	WATER DISTRIBUTOR	911
11	CURTAIN	6095A
12	CONNECTING TUBE PUMP	6126
13	WATER PUMP SUPPORT	31997
	WATER PUMP SUPPORT before 18233810	4956
14	WATER PUMP 115V/60HZ	32065
15	WATER PUMP SUCTION TUBE	4961
16	WATER PUMP TRAY	4521
17	WATER DRAIN DISTRIBUTOR	31723
18	DRAIN TUBE	31722
19	INLET WATER VALVE 1B 115V/60HZ (AIR COOLED)	31925
20	INLET WATER VALVE 2B 115V/60HZ (WATER COOLED)	2793
21	THERMOSTAT TUBE	5437
22	JOINT	666
23	WATER RESTRICTOR	6403

S-41

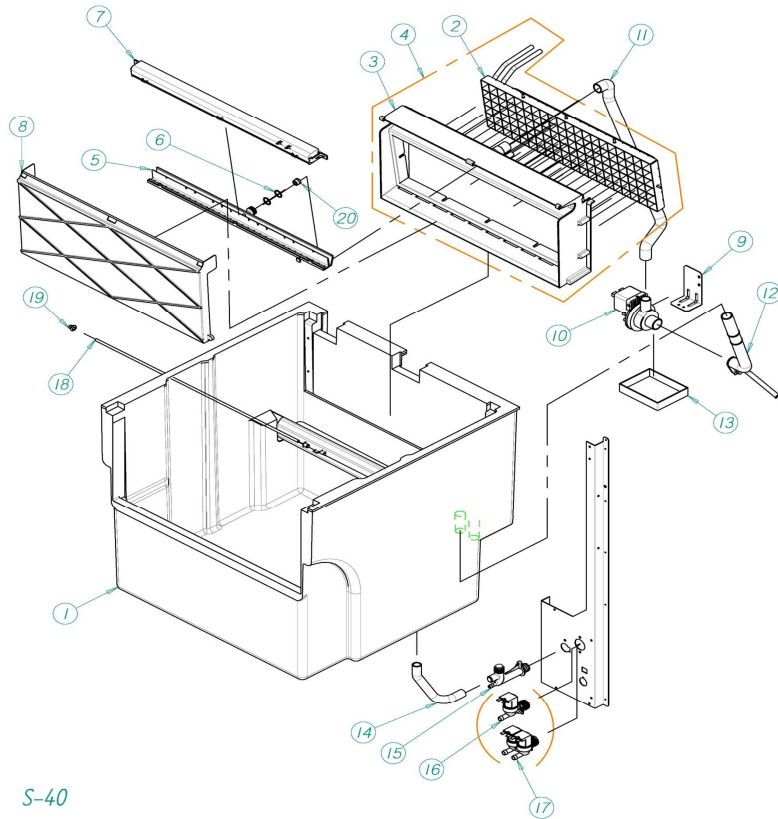

	DESCRIPTION	MODEL		
		175	215	285
1	STOCK BIN	6246		6247
EVAPORATOR				
2		1"	6229	6235A
		1/2"	6232A	6238A
3	FRAME		6091	6092
FRAME AND EVAPORATOR ASSEMBLY				
4		1"	6230	6236
		1/2"	6233	6239
5	COMPLETE WATER DISTRIBUTOR		30039	30040
6	JOINT		4496	
7	WATER DISTRIBUTOR CAP		30039	30040
8	CURTAIN		6093	6094
9	WATER PUMP SUPPORT		31977	
	WATER PUMP SUPPORT before 18233810		4956	
10	WATER PUMP 115V/60HZ		32066	32067
11	WATER IMPULSE PIPE		6128	
12	WATER SUCTION PIPE		4961	
13	WATER TRAY		4521	
14	DRAIN TUBE		31722	
15	WATER DRAIN DISTRIBUTOR		31723	
16	INLET WATER VALVE (AIR COOLED) 115V/60Hz		31925	
17	INLET WATER VALVE (WATER COOLED) 115V/60Hz		2793	
18	THERMOSTAT TUBE		6384	6385
19	JONT		666	
20	WATER RESTRICTOR		6414	

AIR CONDENSER



SPIKA NG

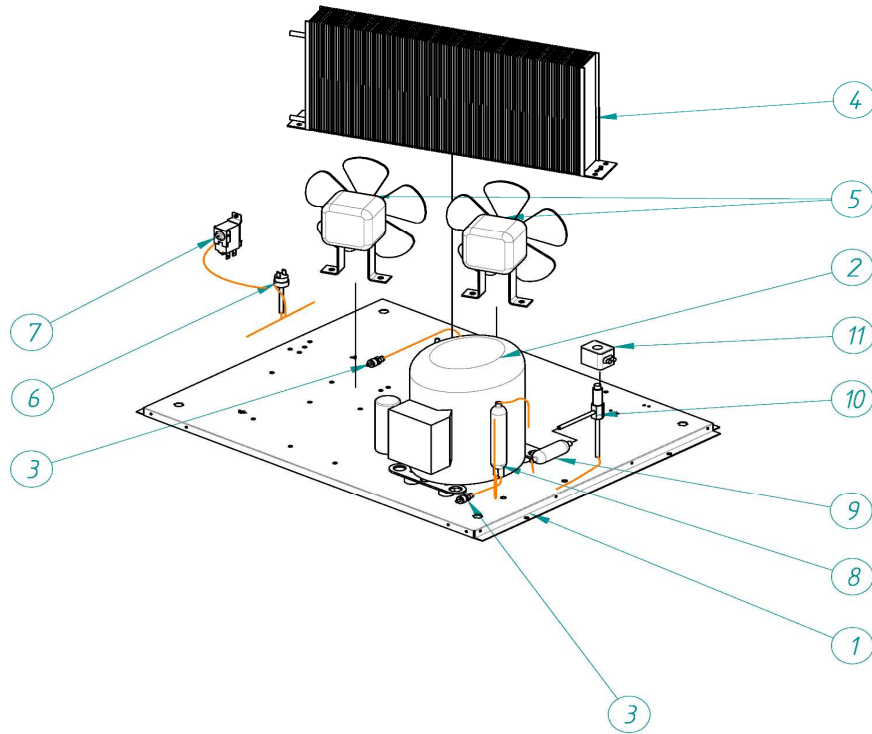

	DESCRIPTION			
	125	175	215	285
1	BASEMENT	4160	6256	6257
2	COMPRESSOR 115V/60Hz	82801	6169	6170
3	REFRIGERANT LOAD VALVE		335	
4	CONDENSER	2541	487	2867
5	FAN MOTOR		4890	2164
	FAN BLADE		4887	4040
6	HIGH PRESSURE SWITCH		334	
7	FRAN CYCLE SWITCH	7476E		2507
8	FILTER DRIER	449		2560
9	FILTER STRAINER		448A	
10	HOT GAS VALVE - BODY	1468	1473	762
11	HOT GAS VALVE - COIL 115V/60Hz			5414
	EXPANSION VALVE	-		6348

WATER CONDENSER



SPIKA NG

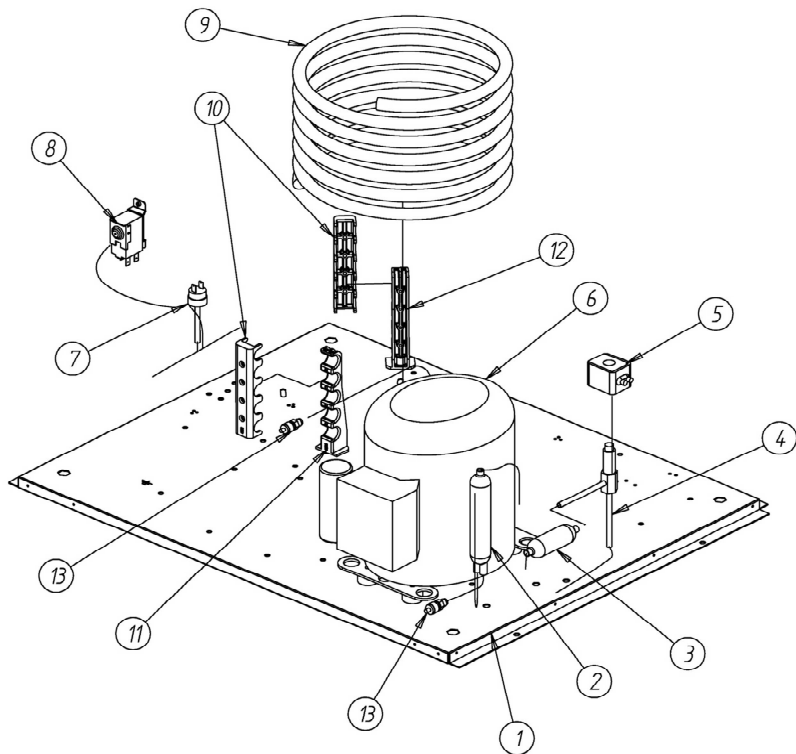

	DESCRIPTION	MODEL			
		125	175	215	285
1	BASEMENT	4160		6256	6257
2	DRIER	449		2560	
3	FILTER STRAINER			448A	
4	HOT GAS VALVE - BODY	1468	1473	762	1473
5	HOT GAS VALVE - COIL 115V/60Hz			5414	
6	COMPRESSOR V 115V/60Hz	82801	6169	6170	6171
7	HIGH PRESSURE SWITCH			334	
8	FAN CYCLE SWITCH	7476E		2507	
9	WATER CONDENSER	5242		5244	
10	WATER CONDENSER SUPPORT	4032		4038	
11	WATER CONDENSER SUPPORT			4037	
12	WATER CONDENSER SUPPORT			4036	
13	REFRIGERANT LOAD VALVE			335	
	EXPANSION VALVE	-		6348	

ELECTRIC BOX

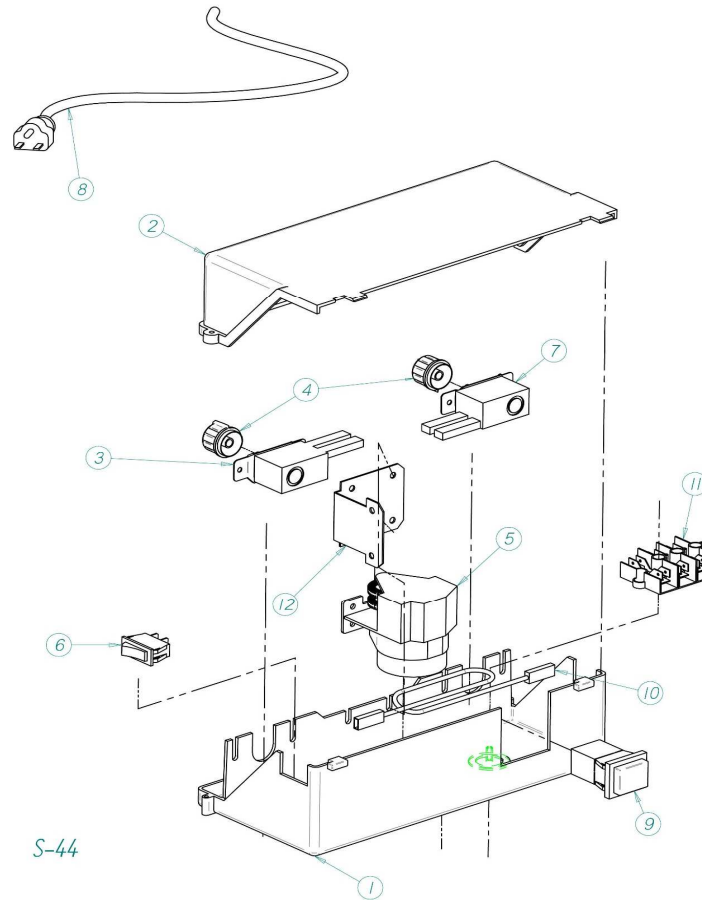

S-44

	DESCRIPTION			
	125	175	215	285
1	ELECTRIC BOARD		4789	
2	ELECTRIC BOARD COVER		4790	
3	ICE THICKNESS CYCLE THERMOSTAT		153	
4	THERMOSTAT BUTTON		272	
5	10' TIMER 115V/60Hz		6250C	
6	CLEANING SWITCH		2300	
7	STOCK/BIN THERMOSTAT		274	
8	CORD + PLUG 115V/60Hz		2771	
9	MAIN POWER SWITCH		2287	
10	RESISTENCE HEATER PVC 115V		4867	
11	CONNECTION POINT TERMINAL		5177 X 3	
12	TIMER PLATE SUPPORT		6248	